

# JF-17 THUNDER

ANALISIS PERFORMA DESAIN PESAWAT JET

**OPENFOAM®**



# Daftar Konten

- **Geometry**
- **Mesh**
- **Patch**
- **Hasil Simulasi**
  - **Kecepatan**
  - **Coefficient Drag (Cd) - Coefficient Lift (Cl)**

# Geometry

## Enclosure

### Gambar Enclosure (ISO)

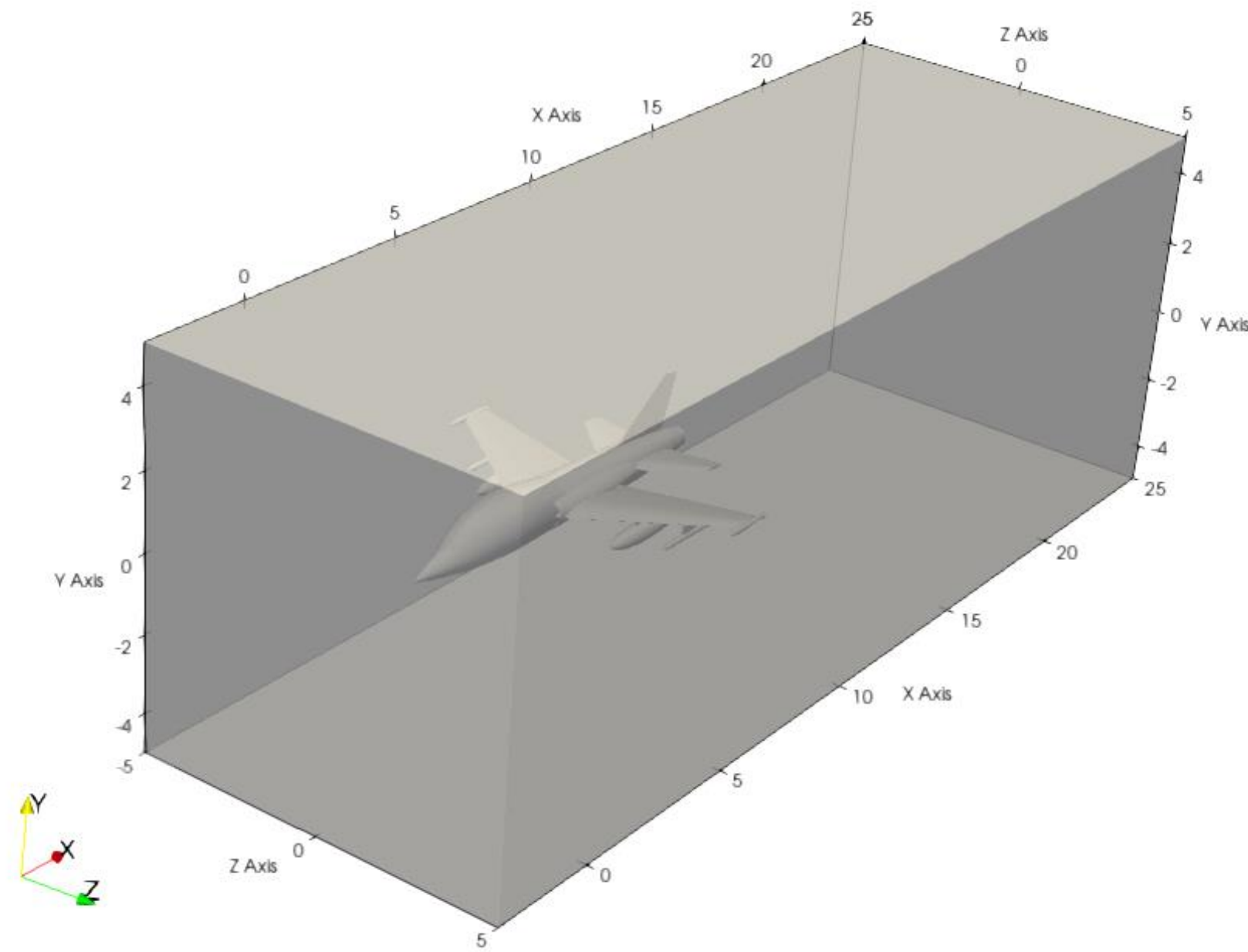

### Gambar Enclosure (Depan)

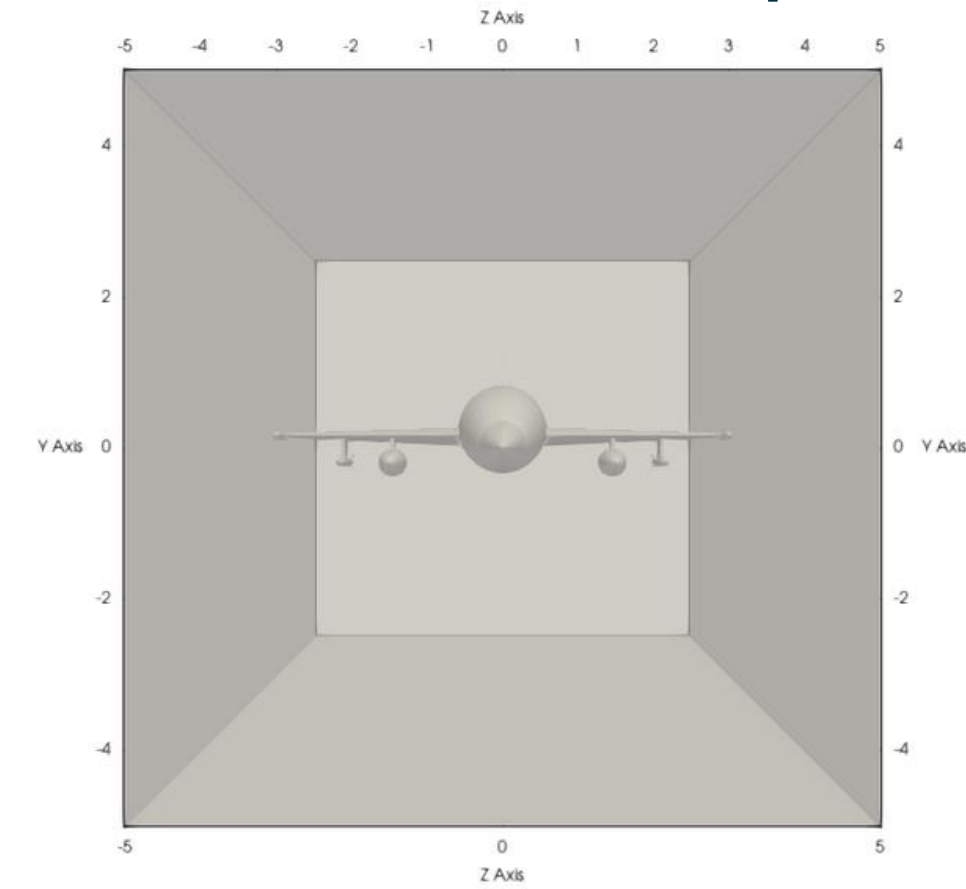

### Gambar Enclosure (Samping)

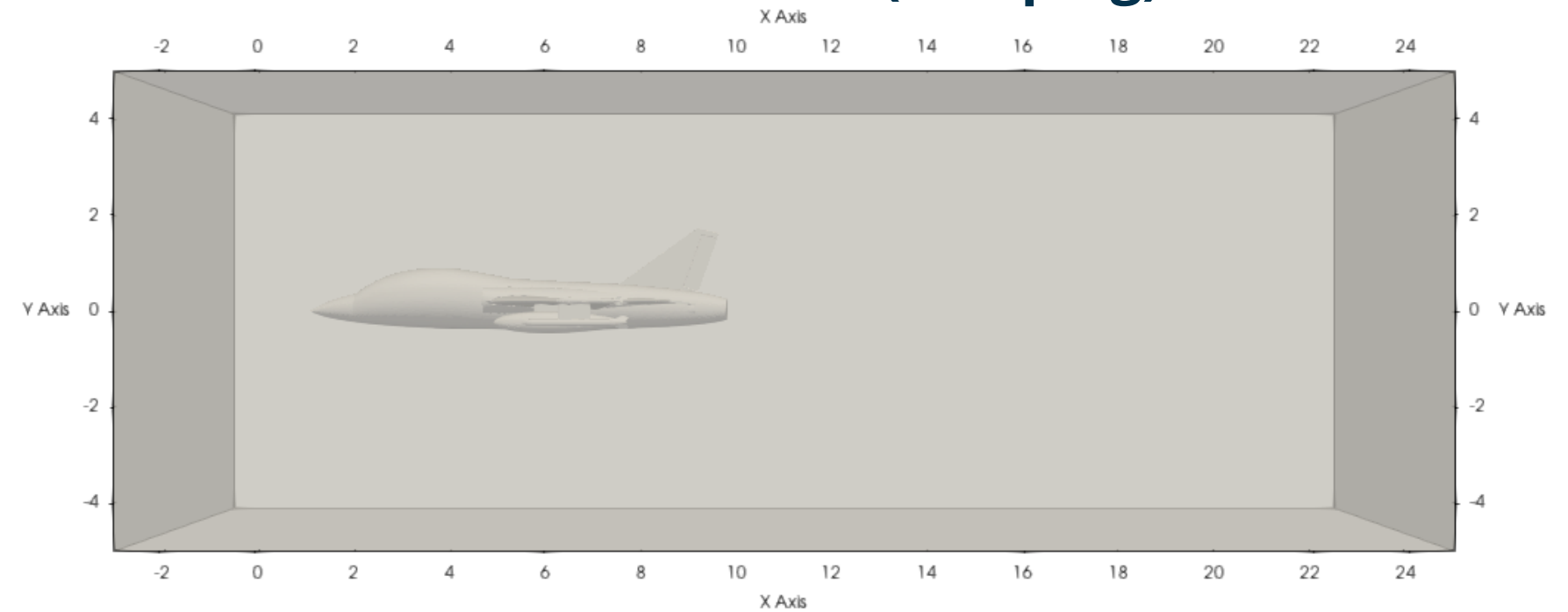

# Geometry

## Body

### Gambar Body (ISO)

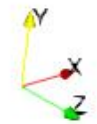
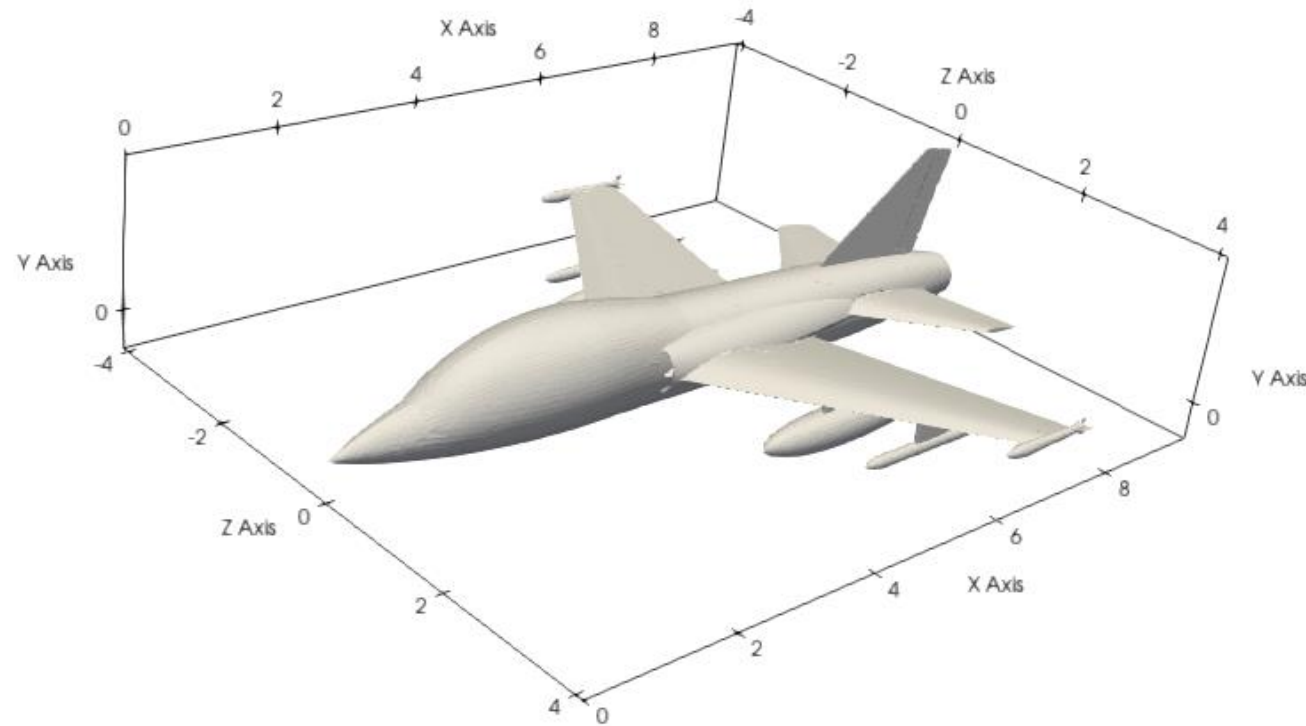

### Gambar Body (Atas)

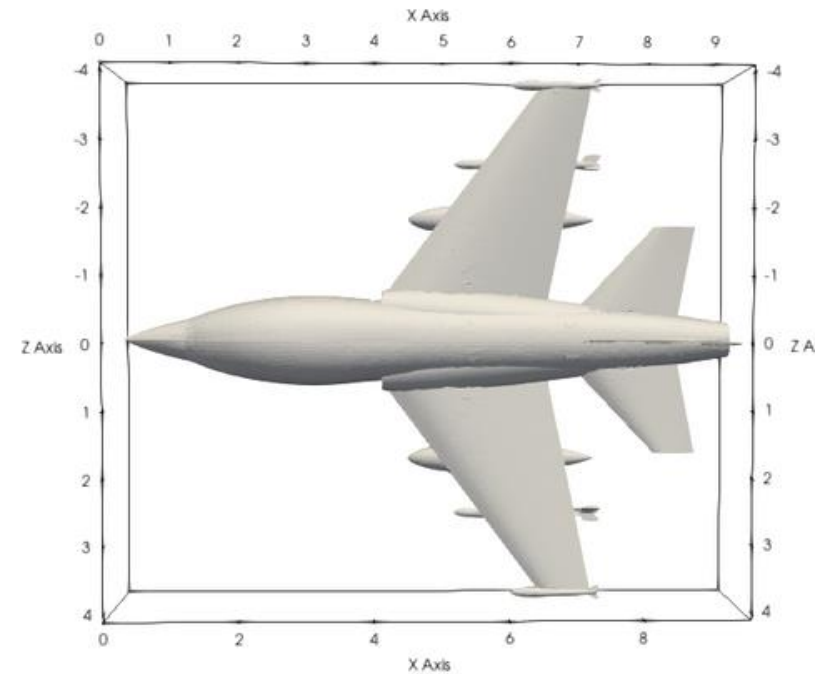

### Gambar Body (Depan)

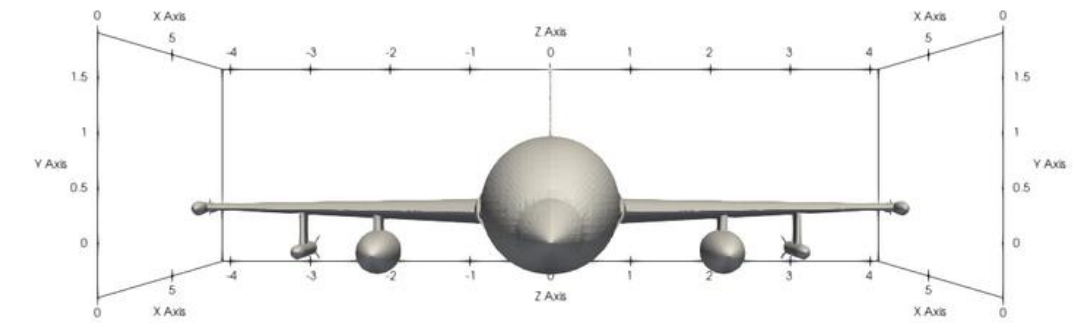

### Gambar Enclosure (Samping)

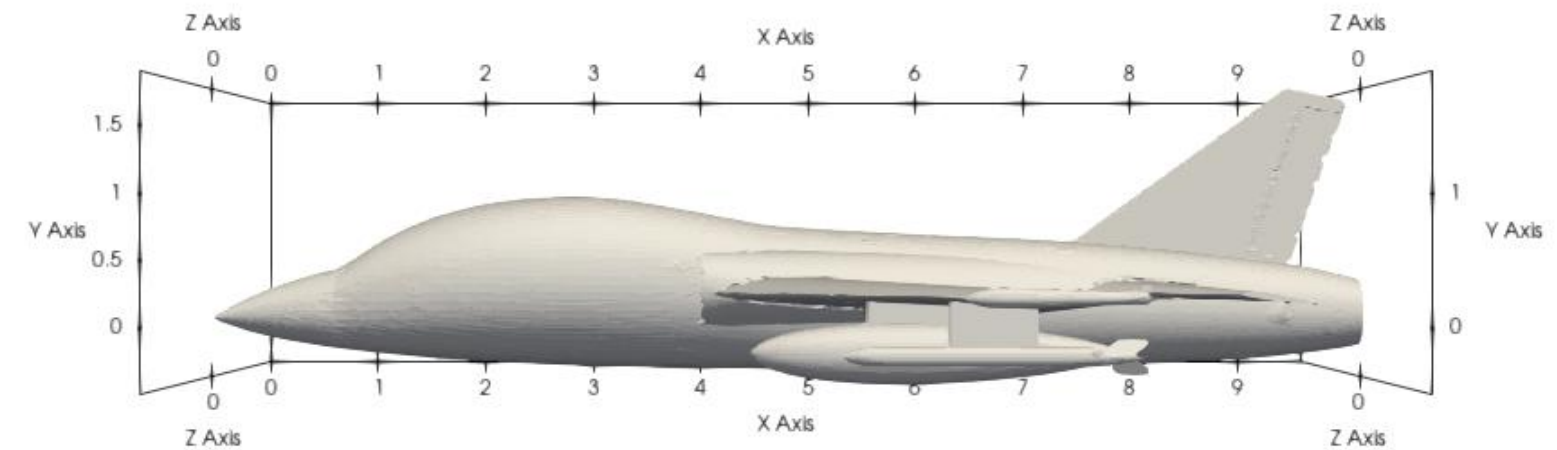

**Gambar Mesh (ISO)**

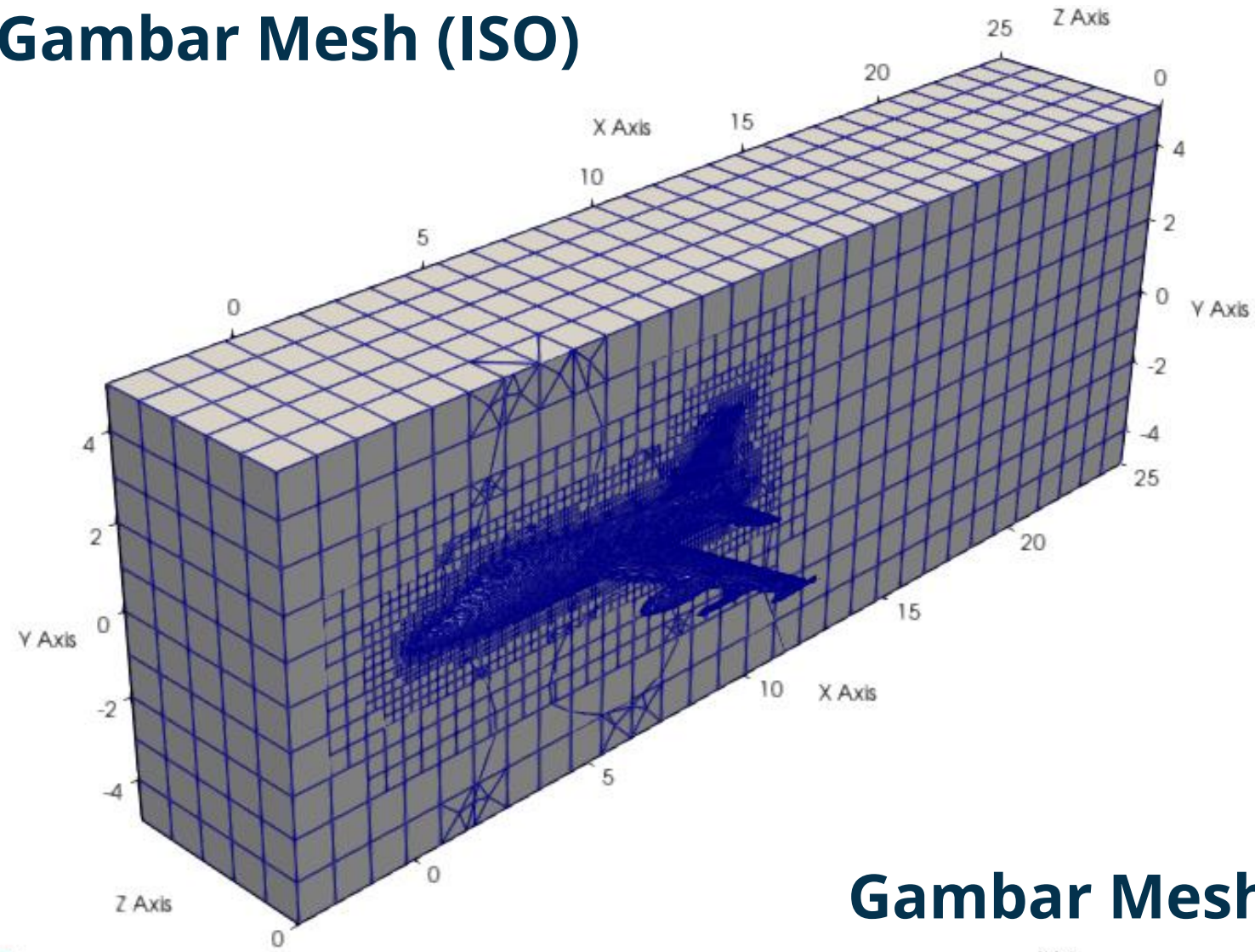

**Gambar Mesh (Depan)**

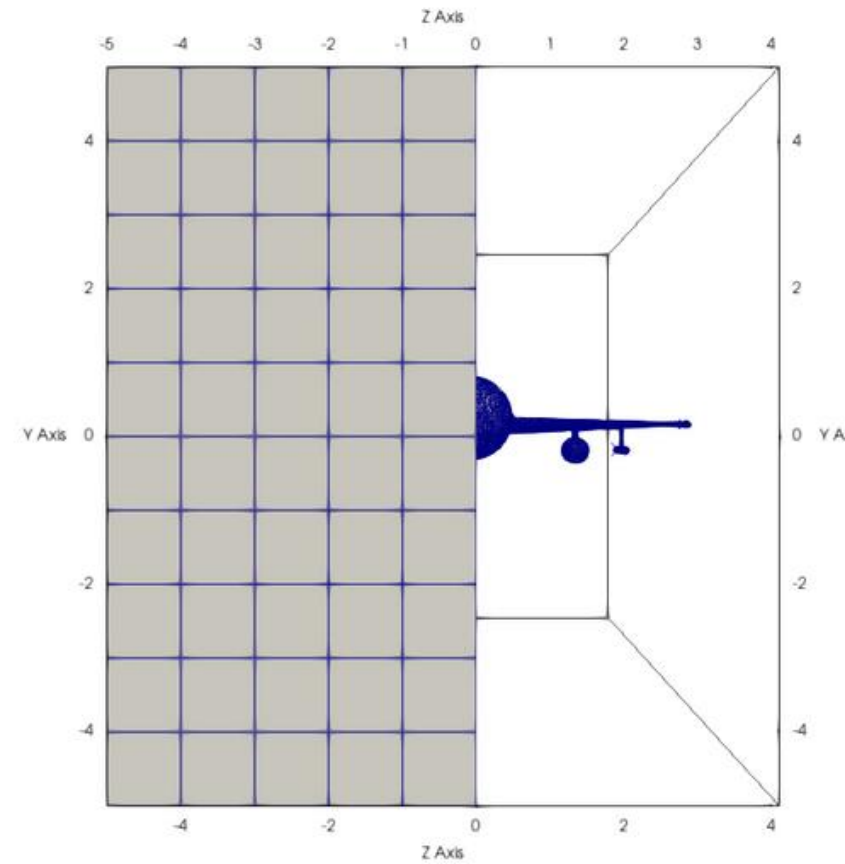

**Mesh**



**Gambar Mesh (JET)**

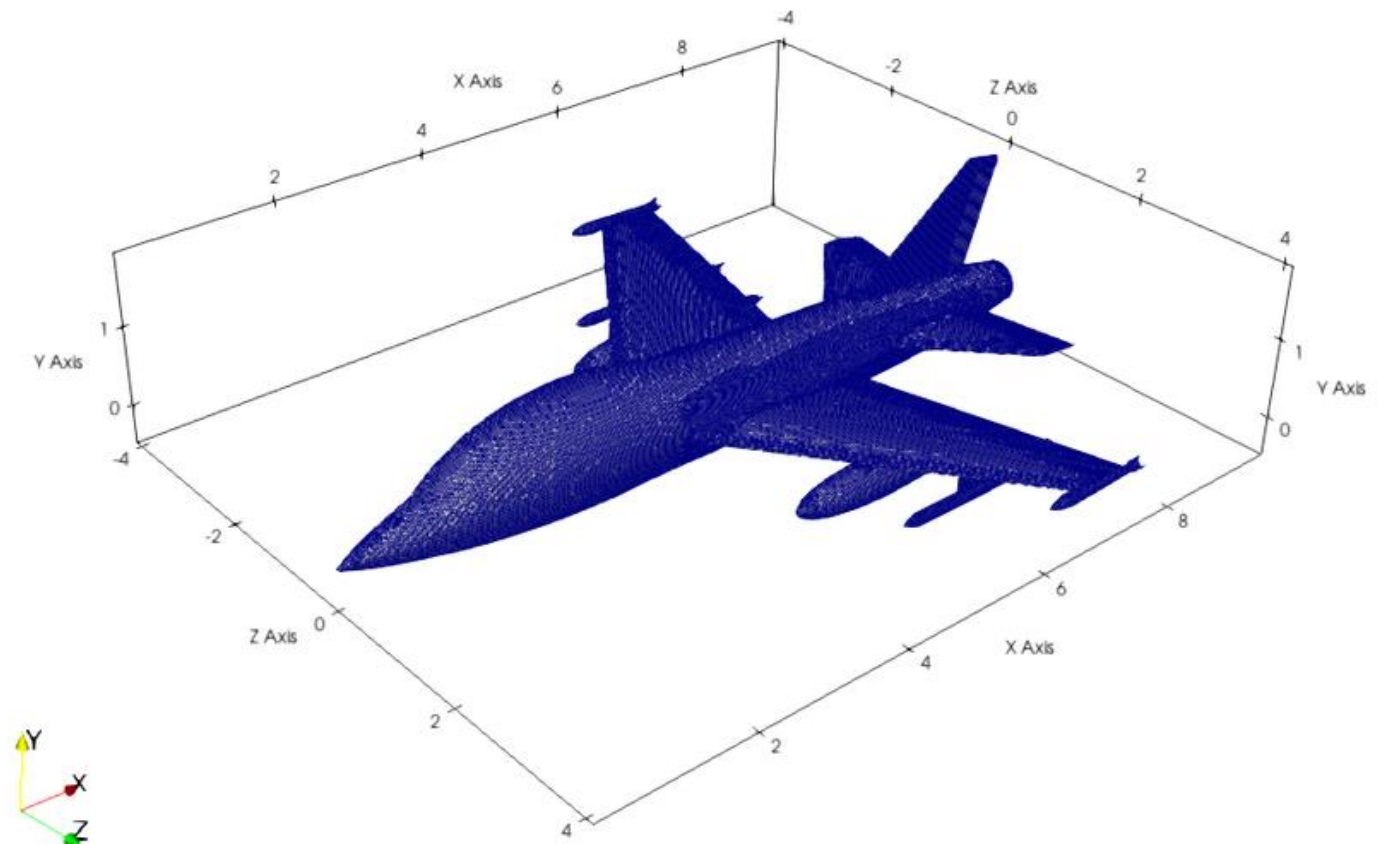

**Gambar Mesh (Samping)**

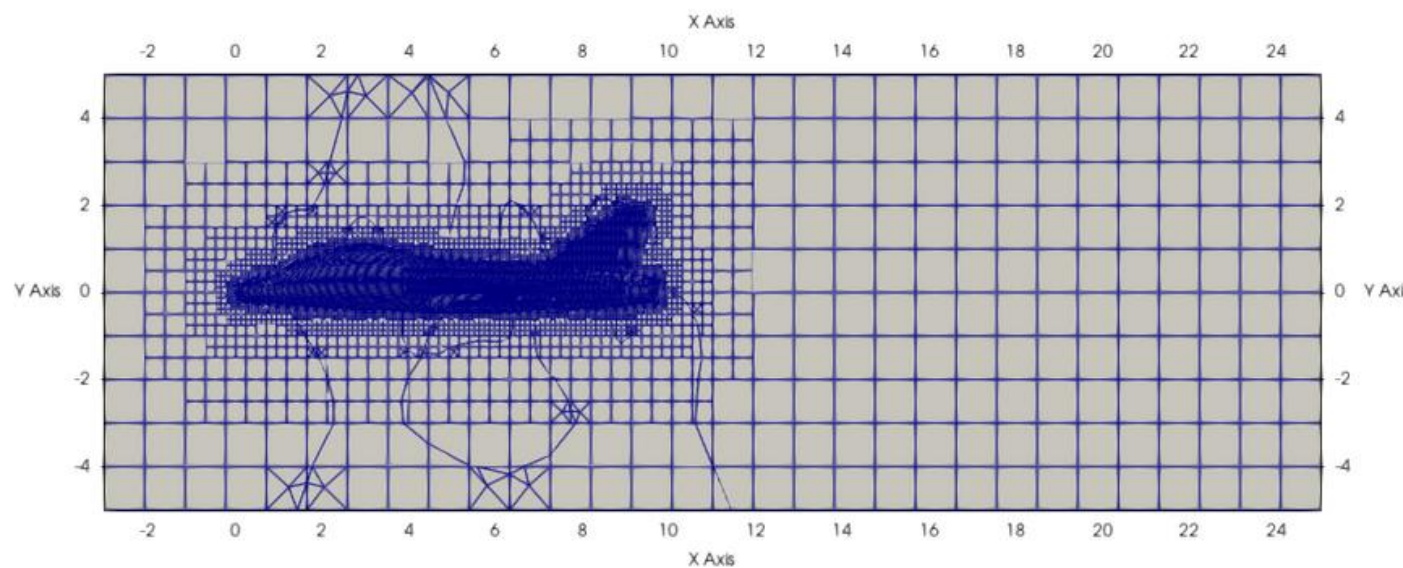

```

Checking geometry...
Overall domain bounding box (-3 -5 -5) (25 5 5)
Mesh has 3 geometric (non-empty/wedge) directions (1 1 1)
Mesh has 3 solution (non-empty) directions (1 1 1)
Boundary openness (8.9026e-19 -2.10527e-17 -1.09591e-16) OK.
Max cell openness = 4.4214e-16 OK.
Max aspect ratio = 9.88568 OK.
Minimum face area = 4.54944e-06. Maximum face area = 1.00048. Face area magnitudes OK.
Min volume = 2.62624e-07. Max volume = 0.933808. Total volume = 2789.27. Cell volumes OK.
Mesh non-orthogonality Max: 64.8861 average: 11.0169
Non-orthogonality check OK.
Face pyramids OK.
***Max skewness = 5.34779, 4 highly skew faces detected which may impair the quality of the results
<<Writing 4 skew faces to set skewFaces
Coupled point location match (average 0) OK.

```

```

Mesh stats
points:      1210867
faces:      3093271
internal faces: 2877979
cells:      949940
faces per cell: 6.28592
boundary patches: 7
point zones: 1
face zones: 0
cell zones: 0

Overall number of cells of each type:
hexahedra:  775153
prisms:    35798
wedges:    0
pyramids:  0
tet wedges: 597
tetrahedra: 16
polyhedra: 138376

```



NO	Item	Max	Average
1	Skewness	5,3479%	-
2	Non-Orthogonality	64,8861%	11,0169%
3	Nodes	1.210.867	-
4	Element	949.940	-
5	Faces	3.093.271	-

**Patch  
Boundary**

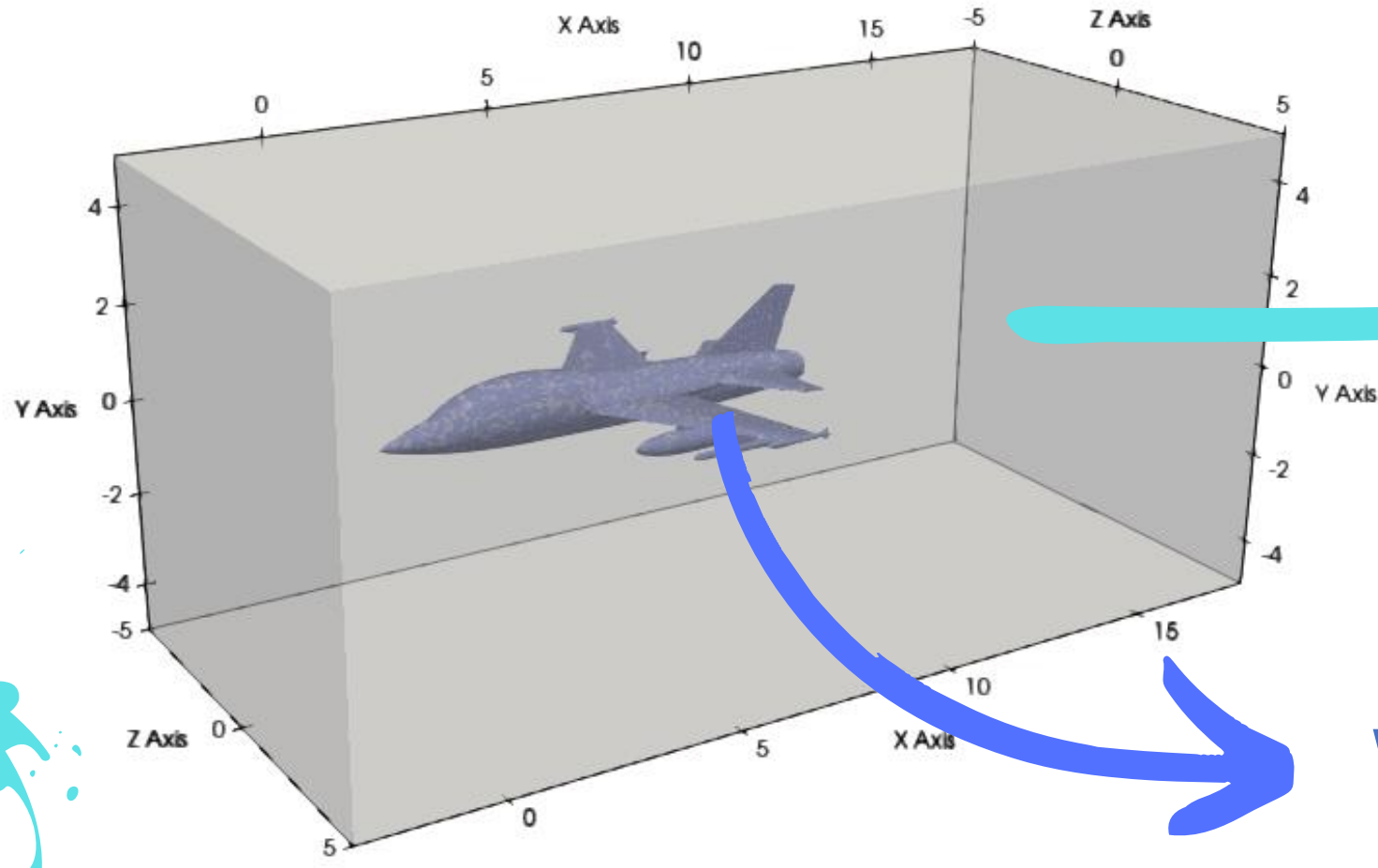

**Domain Fluida**

**Wall Jet Body**

**Inle**

$v = 540 \text{ km/jam}$   
 $\rho = 1,2 \text{ kg/m}^3$

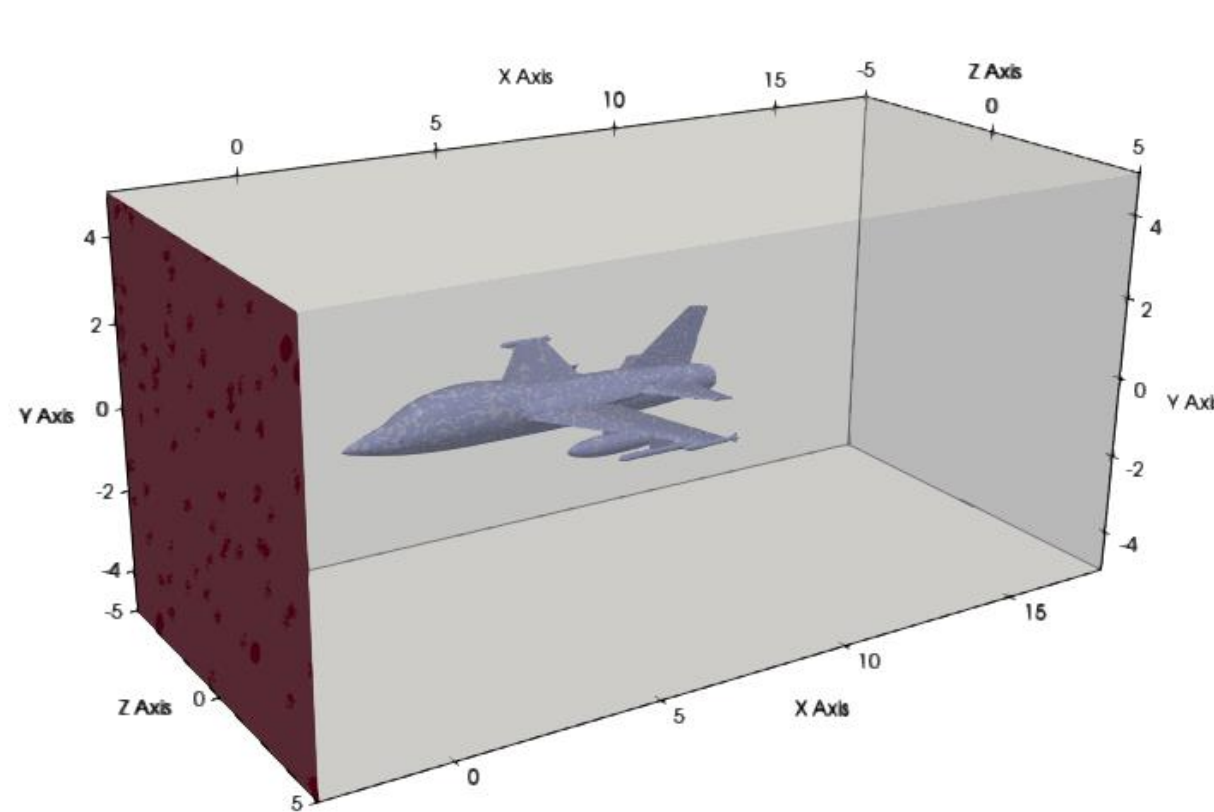

**Outle**

$P = 1 \text{ atm}$   
 $t$

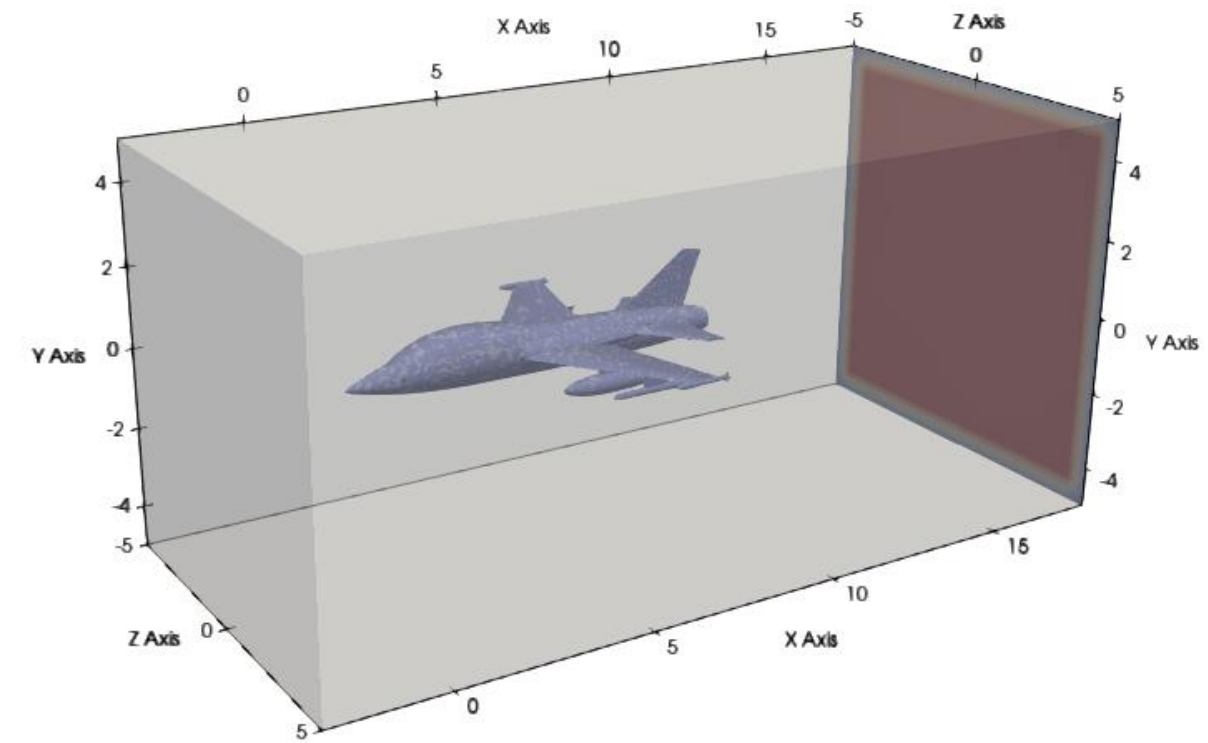

# HASIL SIMULASI



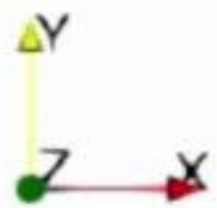
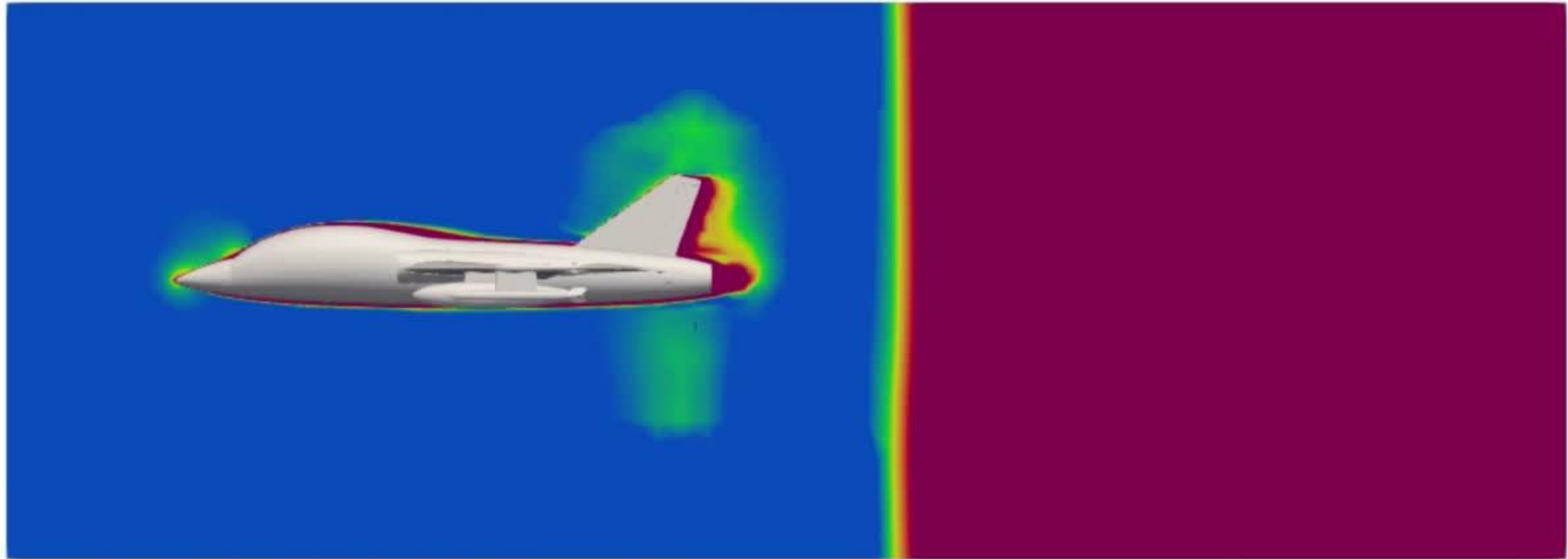

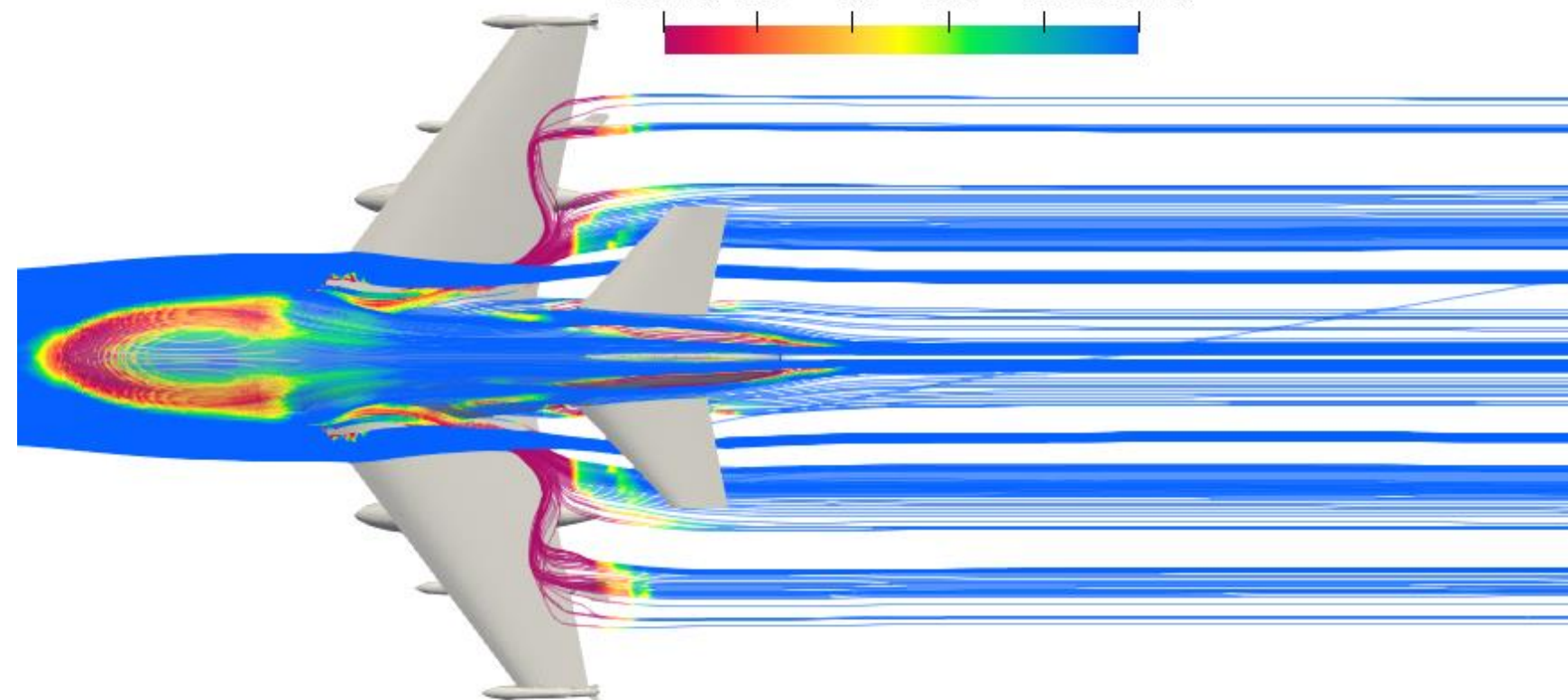
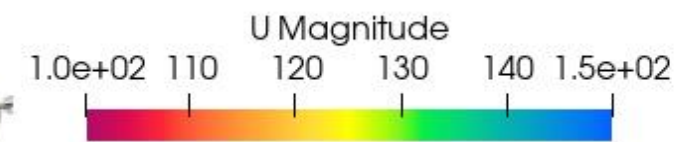
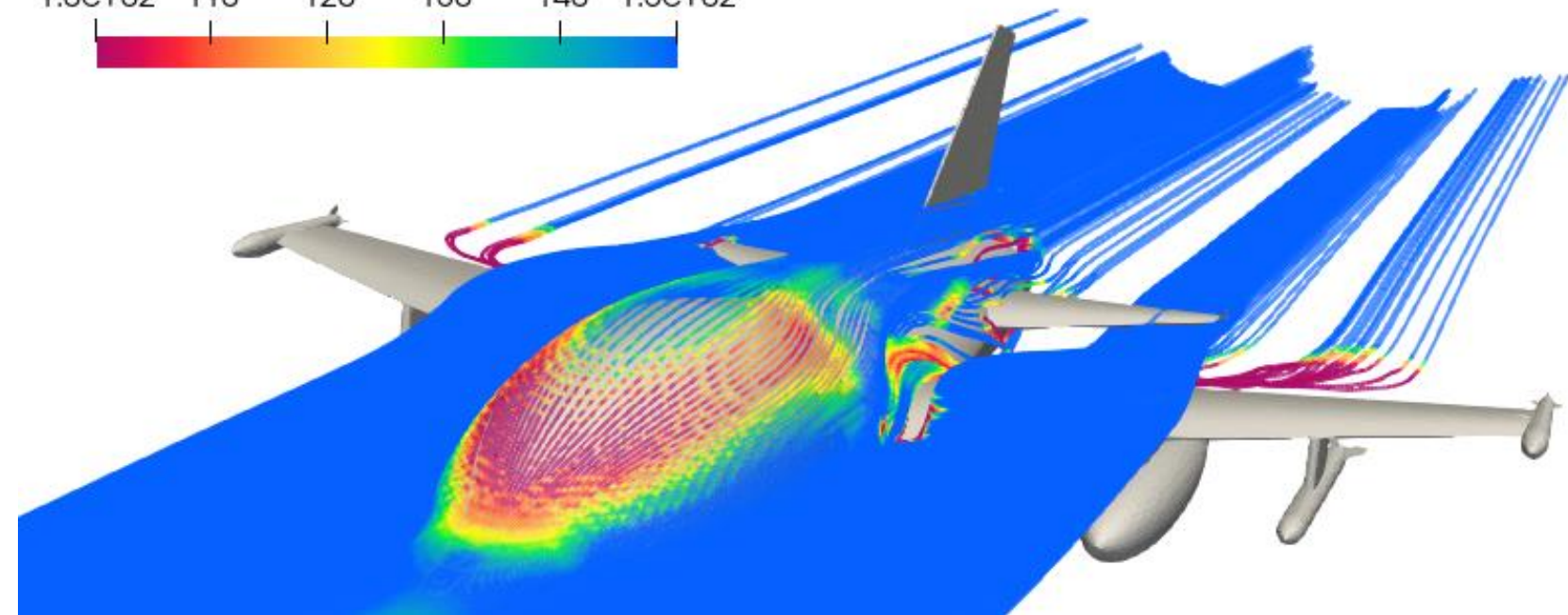
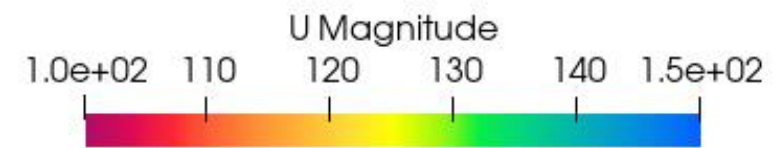
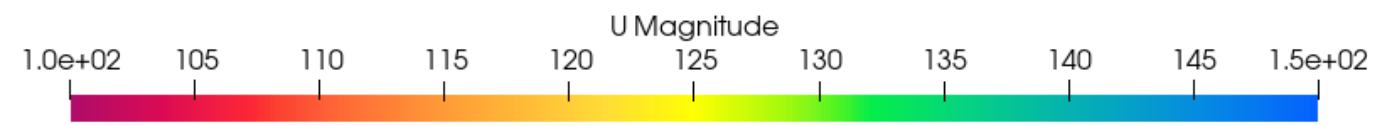

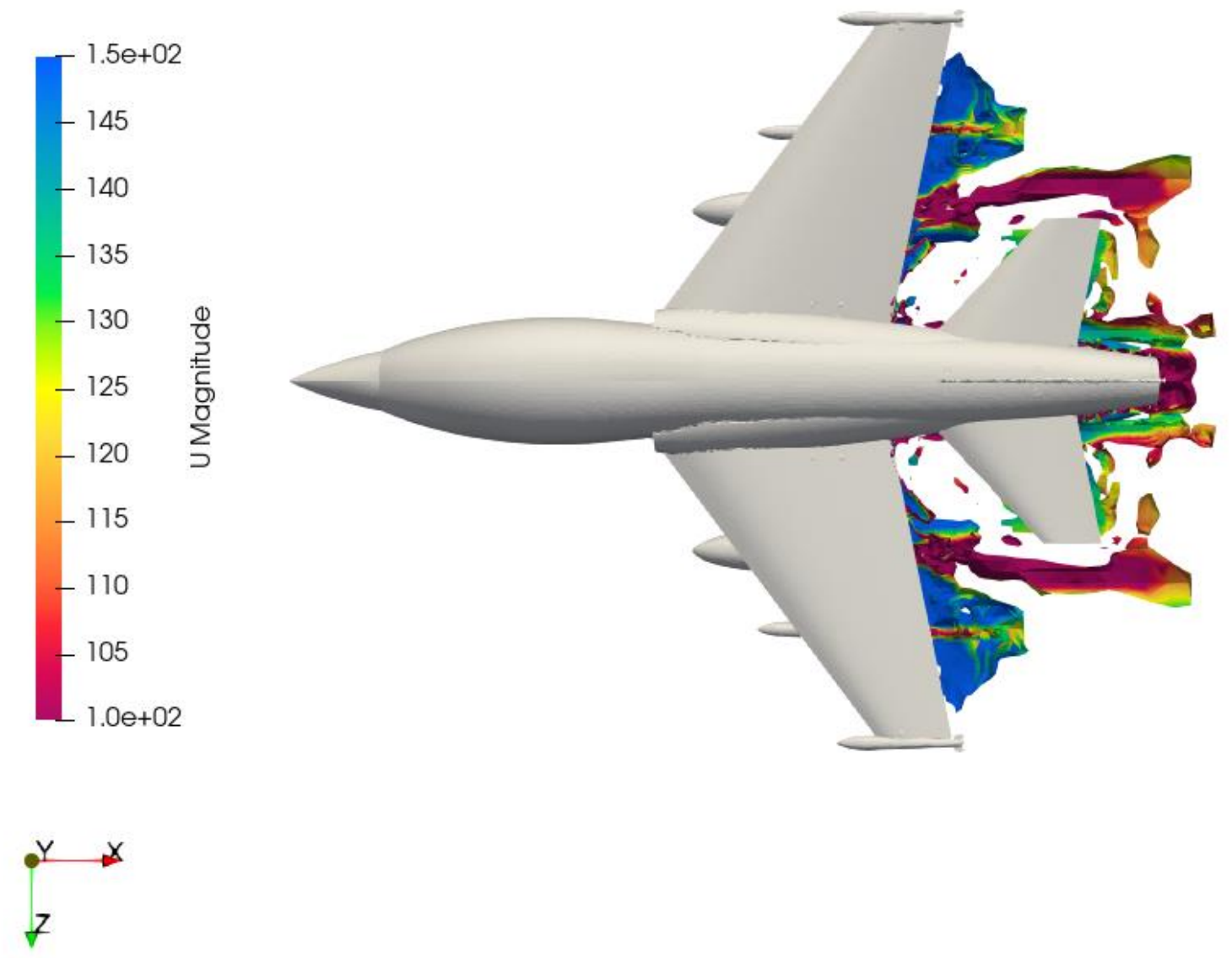
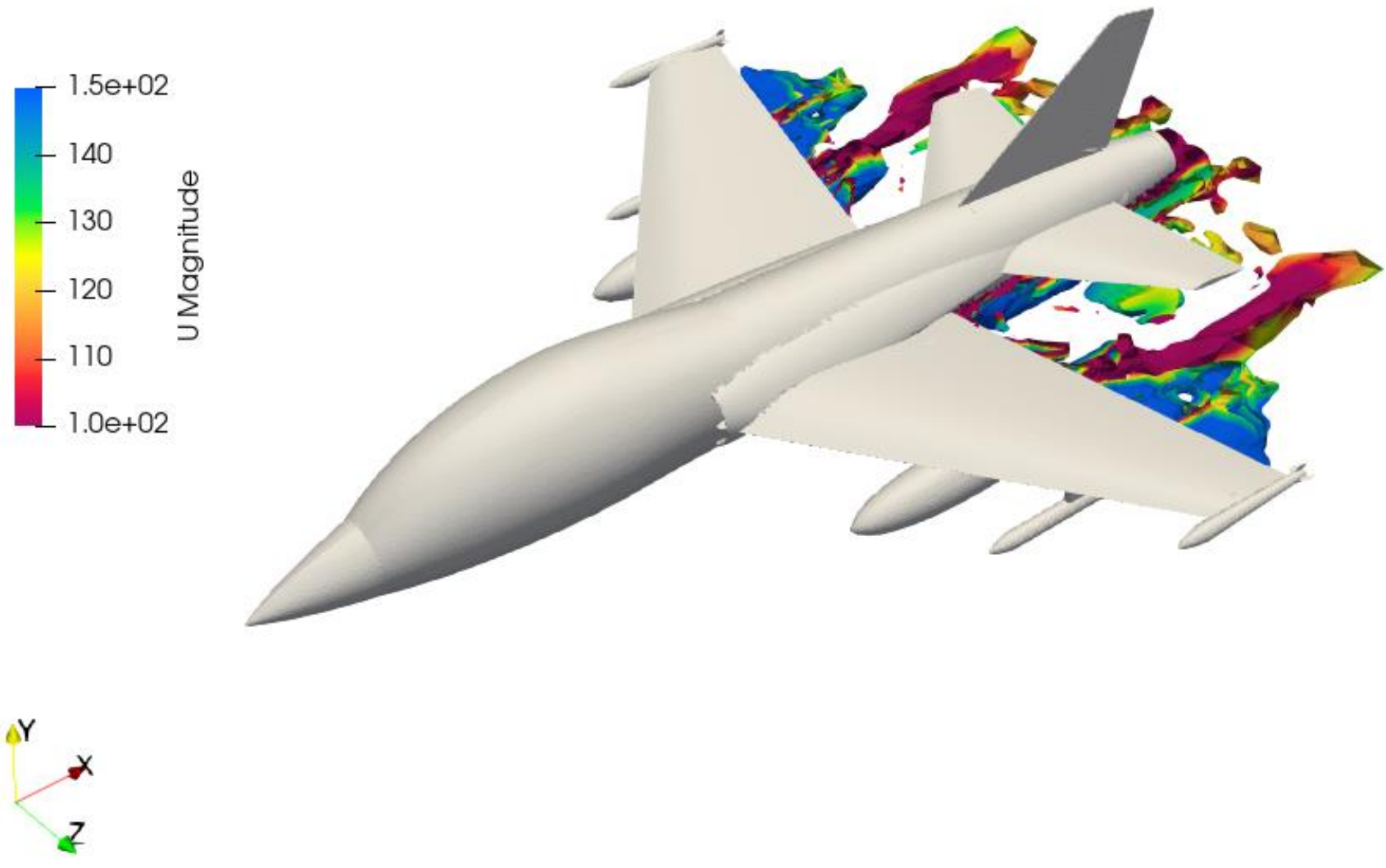

# Grafik Gaya Akumulasi pada Desain Jet

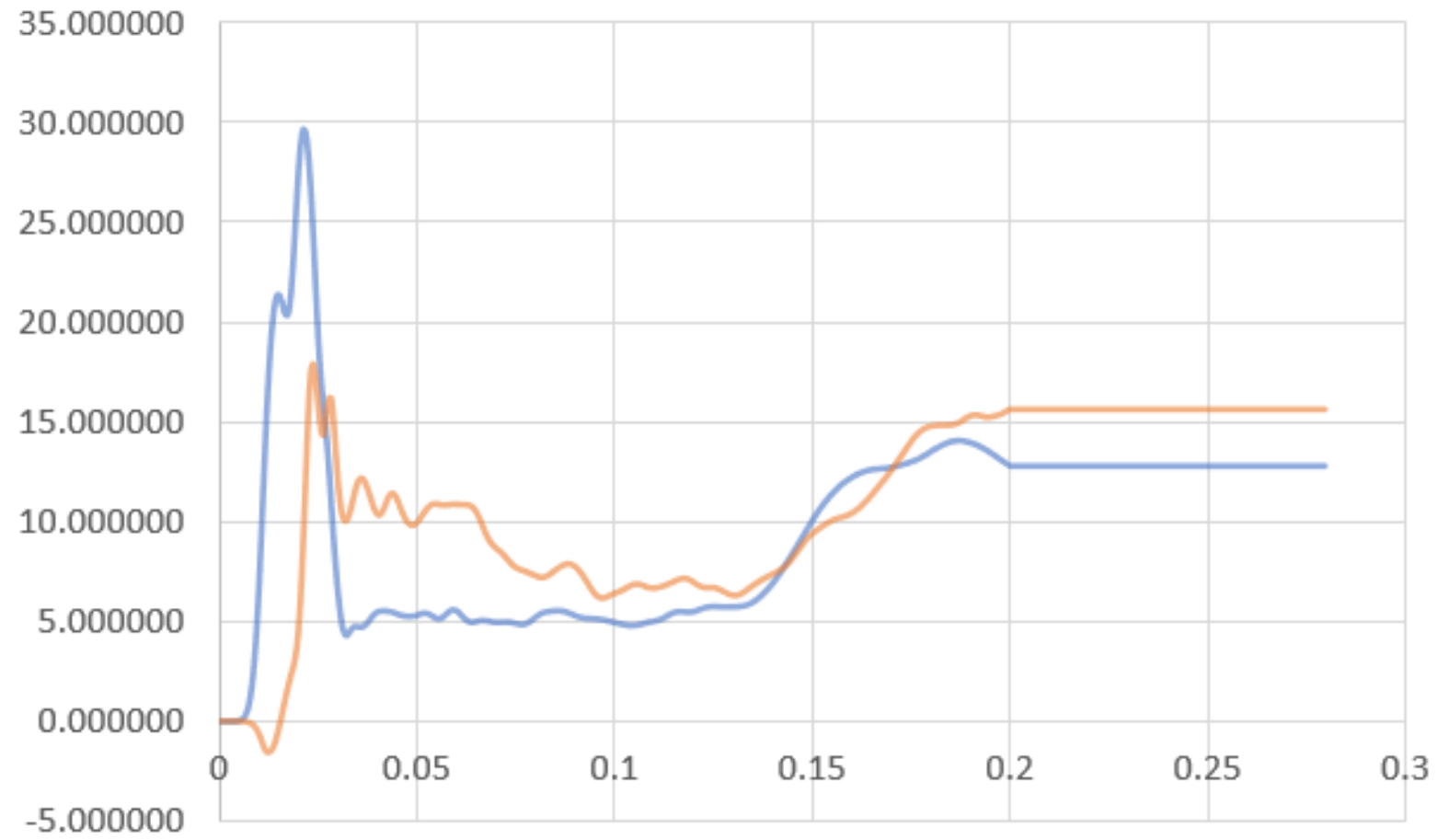

Cl  
Cd

Name	Averaged Value	Maximum	Progress
Cd	9,77	29,02	100%
Cl	10,852	17,851	100%